

# 1/4-14 Impax Lap Panel to Panel Fastener

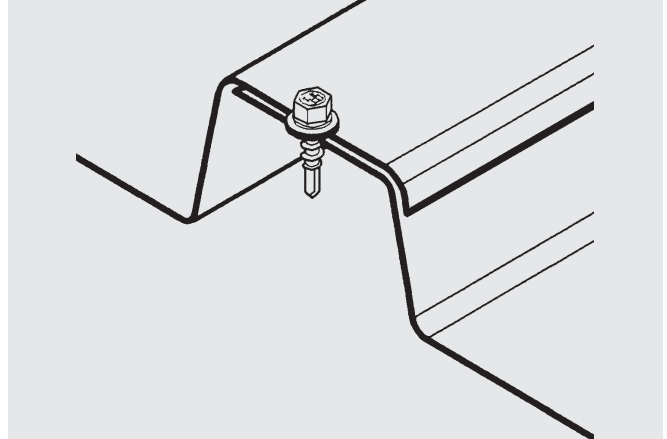

## Features and Benefits

- High hex washer head provides driving stability
- Self-drill point for fast installation
- Available with no sealing washer or with bond seal washer
- VistaCoat® premium coating system
- VistaCoat® limited warranty

## Application

Panel to panel side lap, end lap, and other stitch applications

## Product Selection

Material No.	Fastener Length	Thread Length*	Description	Carton Wt. (lbs.)	Carton Qty.
1304321	7/8"	Full	SDL-#14x7/8-HW5/16-GB9/16	38	2,500

Plain product bagged 250 pieces, unless otherwise noted.

\*Note – Thread length measured from end of pilot length to end of the threads.

# 1/4–14 Impax Lap Panel to Panel Fastener

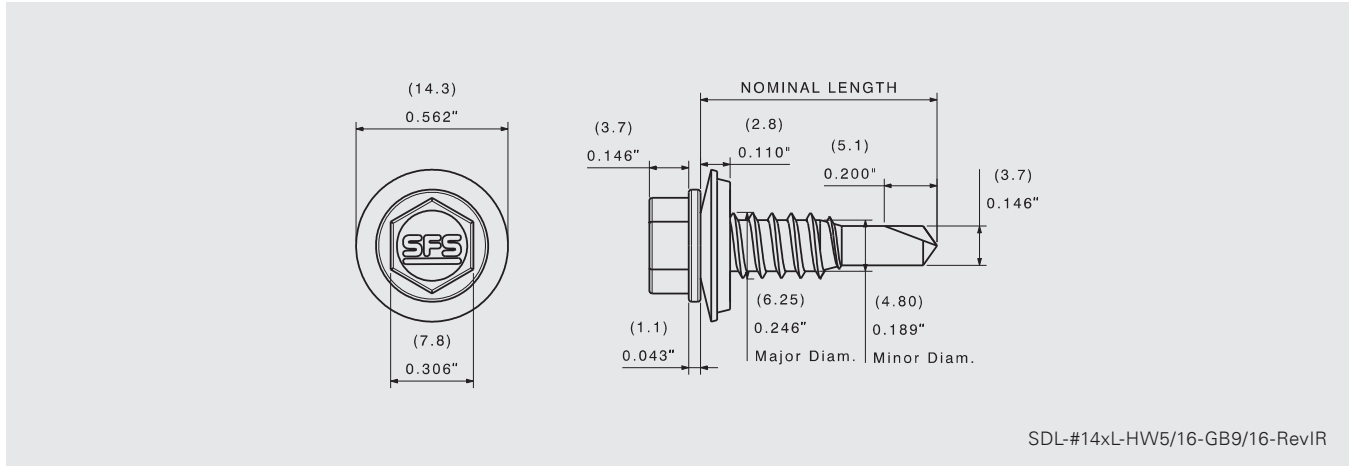

SDL-#14xL-HW5/16-GB9/16-RevIR

## Product Specifications

Diameter: 1/4"  
 Threads Per Inch: 14  
 Head Style: 5/16" dia. HWH AF (7.8 mm)  
 Washer: 9/16" Galvanized and EPDM bond seal (1 mm)

Drill Point: SD1  
 Drill Capacity: 0.030–0.095" (0.762 mm–2.413 mm)  
 Thread Major Dia: 0.246" (6.25 mm)  
 Thread Minor Dia: 0.189" (4.8 mm)

## Performance Data<sup>1,2</sup>

### Material Strength

Tensile	3600 lbf / 16020 N
Shear	2700 lbf / 12015 N
Torsional	150 lbf-in / 17 N-m

### Pull Out Strength Steel

<b>26 Ga (0.5 mm)</b>	204 lbf / 907 N
<b>24 Ga (0.6 mm)</b>	304 lbf / 1352 N
<b>22 Ga (0.6 mm)</b>	379 lbf / 1686 N

<sup>1</sup> SFS [5625.19, 3785.02]

<sup>2</sup> PLK 10403

## Installation and Application Considerations

Tools: 0–2000 rpm screw gun equipped with depth sensing nose piece.

Composite thickness should not exceed 0.095" (2.4 mm).

**Use of impact guns or hammer drills is not recommended.**