

H



JAY R. SMITH MFG. CO.®

MEMBER OF MORRIS GROUP INTERNATIONAL
 POST OFFICE BOX 3237
 MONTGOMERY, ALABAMA 36109-0237 (USA)
 TEL: 334-277-8520 FAX: 334-272-7396 www.jrsmith.com



MEMBER OF:

LOCATION

CAULK FERRULE CLEANOUTS WITH ACCESS COVERS

TAPER THREAD PLUG WITH ROUND COVER

FUNCTION: Used in hub openings in drainage piping where a cleanout is required. Ribbing on outside of ferrule prevents turning of ferrule in the caulking lead. Face-of-wall cover is desirable on finished walls.

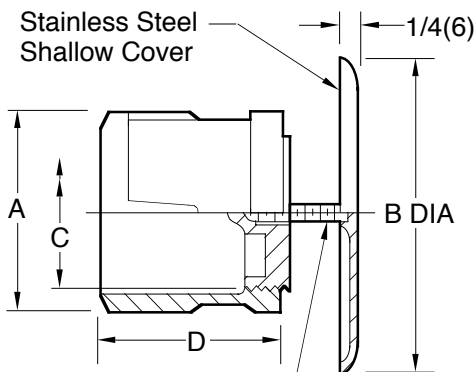

1/4(6) - 20 x 2 1/2(64) Long Flat Head Machine Screw

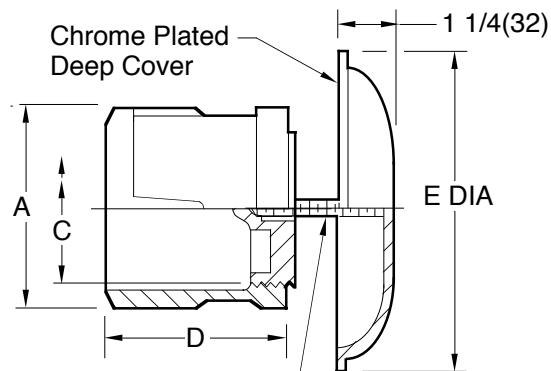

1 1/4(32) - 20 x 1 1/2(38) Long Flat Head Machine Screw

WITH COUNTERSUNK PLUG

- FIG. 4420C LESS COVER AND SCREW
- FIG. 4421C WITH DEEP COVER AND SCREW
- FIG. 4422C WITH SHALLOW COVER AND SCREW

	A SIZE	B DIA	C SIZE	D	E DIA
▲ 02 (50)	4 1/4 (110)	1 1/2 (38)	3 1/2 (89)	*7 1/4 (185)	
▲ 03 (80)	5 1/2 (140)	2 1/2 (64)	3 3/4 (95)	*7 1/4 (185)	
▲ 04 (100)	5 1/2 (140)	3 1/2 (89)	4 1/4 (110)	*7 1/4 (185)	
05 (125)	7 (180)	4 (100)	4 1/4 (110)	*7 1/4 (185)	
06 (150)	9 1/4 (235)	5 (125)	4 1/4 (110)	9 1/4 (235)	
08 (200)	11 1/4 (285)	6 (150)	4 1/2 (115)	11 1/4 (285)	

* = Die Formed SS Cover Only.

OPTIONAL MATERIALS: (4420 & 4422)

- Cast Bronze Ferrule -CB
- Prime Coated Steel Shallow Cover -PC

▲ Sized for Service Weight and/or NO-HUB

REGULARLY FURNISHED:

Duco Cast Iron Caulk Ferrule with Cast Bronze Taper Thread Plug. Type of Cover as Indicated by Figure Number Selected.

VARIATIONS:

- Longer Screw 6"(150) Lg. -LS
- "T" Handle Plug -TH
Plug Tapped 1/4"(6) -20 Thread
- Vandal Proof Screw-U

OPTIONAL MATERIALS: (4421)

- Cast Bronze Body -BB
- Nickel Bronze Deep Cover -NB
9 1/4"(235) & 11 1/4"(285) sizes only
- Polished Bronze Deep Cover -PB
9 1/4"(235) & 11 1/4"(285) sizes only

NOTE: Dimensions shown in parentheses are in millimeters.

DRAWING NUMBER
S4420

SIZE
A

SCALE:
NONE

DATE:
2-16-70

APPROVED BY:
BH

CHECKED BY:
BH

DRAWN BY:
RK

4420 SERIES

FIGURE NUMBER

WE CAN ASSUME NO RESPONSIBILITY FOR USE OF SUPERSEDED OR VOID DATA

DIMENSIONS ARE SUBJECT TO MANUFACTURERS TOLERANCE AND CHANGE WITHOUT NOTICE

REV.	DATE	DESCRIPTION	BY	CKD. BY
H G F	10-7-14 10-20-98 8-11-97	Revised Variations Revised S.W. and/or N.H Chg'd Var. & Opt. Mat.	TBW TBW EMB	BW JCS BS

WEIGHT POUNDS	VOLUME CUBIC FEET	FIGURE NUMBER
		4420 SERIES