

**TOP VIEW**

9" x 15-1/4" SUPPORT PAD  
\*ACCESSORY ITEM\*

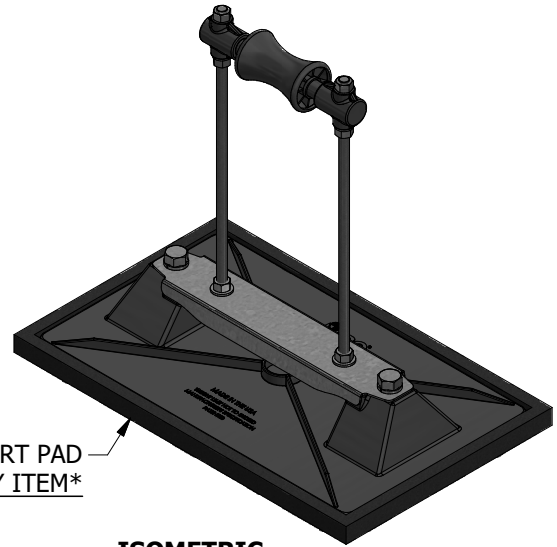

**ISOMETRIC VIEW**

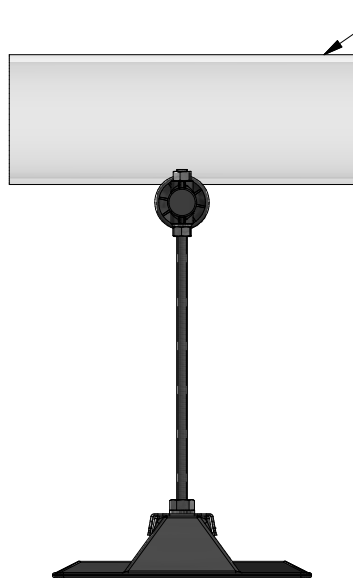

**SIDE VIEW**

4" SCH. 40 PIPE  
ILLUSTRATION ONLY

4-RAH PIPE GUIDE  
\*ACCESSORY ITEM\*

13 5/8" MAX  
4 1/2" MIN

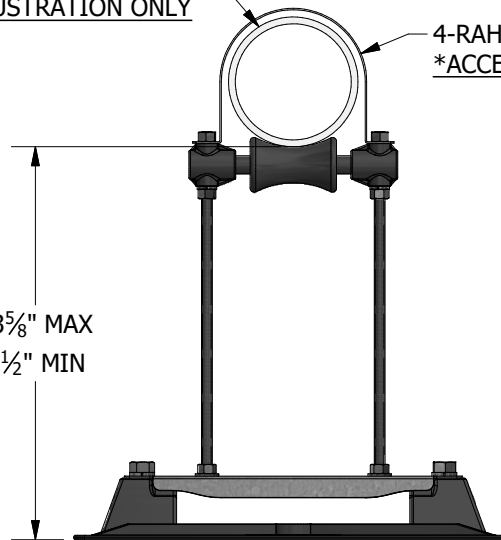

**END VIEW**

**ACCESSORIES**

- Refer to 4-RAH Pipe Guide specification for available sizes.
- 9" x 15 1/4" Support pad
- Eternabond® 2-sided tape

**PRODUCT DESCRIPTION**

A "roller-bearing" pipe support used to support roof-mounted gas pipes, electrical conduit, solar piping and other mechanical piping. Unique design absorbs thermal expansion and contraction of pipes thus preventing damage to the roof membrane. Pipes rest on a self-lubricating polycarbonate resin axle and roller.

**KEY INFORMATION**

- Optimally designed for a 4" pipe.
- Maximum pipe OD (with insulation) is 5-1/2".
- Adjustable from the factory set maximum height of 13-5/8" down to a minimum height of 4-1/2".
- Maximum load is 186 lbs. (All-thread capacity) Make certain each pipe support is properly elevated to evenly distribute weight at all pipe support locations.
- Unit weight: 3.48 lbs.
- 5 per case, 19 lbs., (DW=36 lbs.)
- Recommended spacing is not to exceed 10' centers depending upon the load.
- Base Material: Polycarbonate
- Roller, Axle and Collar Material: Polycarbonate
- 3/8" all-thread is stainless steel
- All other metal parts are hot-dip galvanized

The information contained in this drawing is the sole property of MIRO Industries, Inc. Any reproduction in part or as a whole without written permission of MIRO Industries, Inc. is prohibited.

DATE:  
JAN 2019

4-RAH-14